

OWNER'S MANUAL AND USER'S INSTRUCTIONS

MODEL A-160 HYDRAULIC BRAKE ACTUATOR



TRAILER
Buddy[®]
PRODUCTS BY UFF

*San Marcos, CA * Winchester, TN*

UFP MODEL A-160 ACTUATOR

Model A-160 is a heavy duty surge brake actuator for trailers, which can be equipped to work with one, two or three drum/disc brake axles. When brakes are applied on the towing vehicle, forward inertia of trailer toward towing vehicle applies brakes on trailer in direct relation to manner brakes are applied on towing vehicle. Brake towing vehicle hard and brakes on trailer are applied hard. Master cylinder push rod spring assembly protects system from hydraulic pressure overload.



WARNING: To Prevent Serious Injury or Death

- Review following instructions before installation and use of hydraulic brake actuator.
- Dealers or distributors must review these instructions with ultimate user.
- Failure to follow these instructions, or failure to properly maintain braking system after installation, can result in loss of braking action.



Table of Contents

General information	1
Safety, Signal Words	2
Equipment Safety Guidelines	3
Remember	3
Safety Sign Locations	4
Safety Sign Care	5
Before Operation	5
During Operation	6-7
Following Operation	7
Highway and Transport Operations	7-8
Performing Maintenance	9
Actuator Parts Breakdown and Parts List	10-11
Welding Instructions	12
Hitch Configurations & Bolt/Weight Rating Warning	13
Actuator Installation and Maintenance	14-15
UFP Brake Products Limited Warranty	Back Cover

SAFETY

TAKE NOTE! THIS SAFETY ALERT SYMBOL FOUND THROUGHOUT THIS MANUAL IS USED TO CALL YOUR ATTENTION TO INSTRUCTIONS INVOLVING YOUR PERSONAL SAFETY AND SAFETY OF OTHERS. FAILURE TO FOLLOW THESE INSTRUCTIONS CAN RESULT IN INJURY OR DEATH.



THIS SYMBOL MEANS

ATTENTION

BECOME ALERT

YOUR SAFETY IS INVOLVED!

SIGNAL WORDS

Note use following signal words **DANGER**, **WARNING**, and **CAUTION** with safety messages. Appropriate signal word for each has been selected using following guidelines:

DANGER:

Indicates an imminently hazardous situation that, if not avoided, will result in death or serious injury. This signal word is to be limited to most extreme situations typically for machine components which, for functional purposes, cannot be guarded.

WARNING:

Indicates a potentially hazardous situation that, if not avoided, could result in death or serious injury, and includes hazards that are exposed when guards are removed. It may also be used to alert against unsafe practices.

CAUTION:

Indicates a potentially hazardous situation that, if not avoided, may result in minor or moderate injury. It may also be used to alert against unsafe practices.

If you have questions not answered in this manual, require additional copies, or if your manual is damaged, please contact your dealer or 135 Sunshine Lane, San Marcos, CA 92069, Phone: 1-800-854-1905, Fax (760) 744-1616.

<http://www.ufpnet.com>



SAFETY...YOU CAN LIVE WITH IT



EQUIPMENT SAFETY GUIDELINES

Every year many accidents occur which could have been avoided by a few seconds of thought and a more careful approach to handling equipment. You the operator, can avoid many accidents by observing and following precautions in this section. To avoid personal injury, study the following precautions and insist those working with you, or you yourself, follow them.

In order to provide a better view, certain illustrations in this manual may show an assembly with a safety shield removed. However, equipment should never be operated in this condition. Keep all shields in place. If shield removal becomes necessary for repairs, replace shield prior to use.

Replace any caution, warning, danger or instruction safety decal that is not readable or is missing. Location of such decals is indicated in this booklet.

Do not attempt to operate this equipment under the influence of alcohol or drugs.

Review safety instructions with all users.

Operator should be a responsible adult. **DO NOT ALLOW PERSONS TO OPERATE OR ASSEMBLE THIS UNIT UNTIL THEY HAVE DEVELOPED A THOROUGH UNDERSTANDING OF SAFETY PRECAUTIONS AND HOW IT WORKS.**

Do not paint over, remove, or deface any safety signs or warning decals on your equipment. Observe all safety signs and practice instructions on them.

Never exceed limits of a piece of machinery. If its ability to do a job, or to do so safely is in question-**DON'T TRY IT.**



REMEMBER

Your best assurance against accidents is a careful and responsible operator. If there is any portion of this manual or function you do not understand, contact your local authorized dealer or manufacturer.



SAFETY SIGN LOCATIONS

Types of safety sign and locations on equipment are shown in illustration below. Good safety requires that you familiarize yourself with various safety signs, type of warning, and area or particular function related to that area, that requires your SAFETY AWARENESS.

This decal positioned as shown

**BRAKES ON
DO NOT TOW**

**BRAKES OFF
TOWABLE**

Part #32522

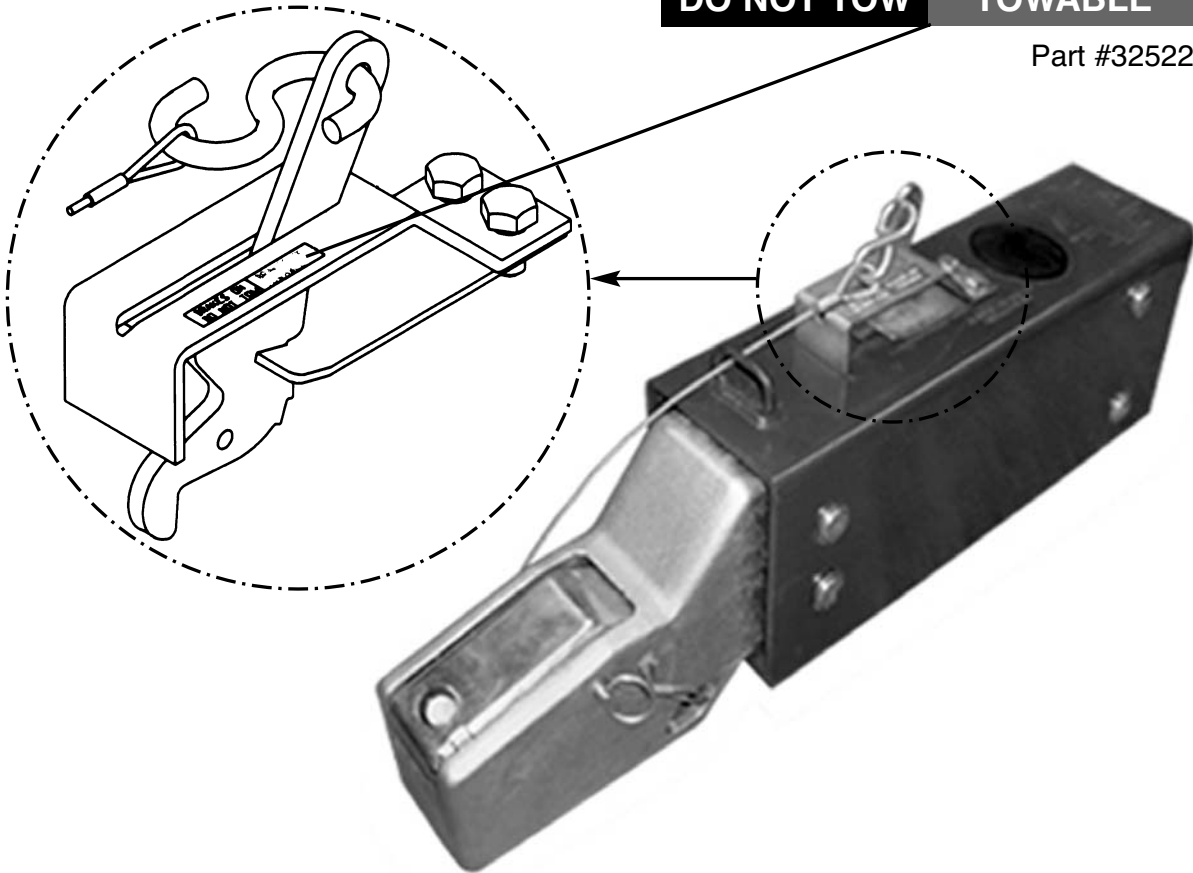

TRAILER BREAKAWAY SYSTEM



WARNING: All actuators must have a way to apply the trailer brakes should the trailer become completely detached from the towing vehicle. The breakaway cable is the third line of defense after trailer separation. Before the breakaway cable is pulled, the coupler must become detached from the hitch ball and then the safety chains must fail. At this time the breakaway cable is pulled which will apply a braking force to the trailer. Note: The breakaway system is not intended to lock up the trailer brakes after tow vehicle separation but rather to apply just enough braking force to keep the trailer from free-wheeling down the road. The breakaway system must be reset manually after it has been activated.

DO NOT USE THE BREAKAWAY SYSTEM AS A PARKING BRAKE.



SAFETY SIGN CARE

- Keep safety signs clean and legible at all times.
- Replace safety signs that are missing or have become illegible.
- Replacement parts that displayed a safety sign should also display safety sign.
- Safety signs are available from your distributor or factory.

How to install safety signs:

- Be sure that installation area is clean and dry.
- Decide on exact position before you remove backing paper.
- Remove smallest portion of split backing paper.
- Align decal over specified area and carefully press small portion with exposed sticky backing in place.
- Slowly peel back remaining paper and carefully smooth remaining portion of decal into place.
- Small air pockets can be pierced with a pin and smoothed out using piece of decal backing paper.



BEFORE OPERATION:

- Carefully study and understand this manual.
- Give equipment a visual inspection for any loose bolts, worn parts, or cracked welds, and make necessary repairs. Follow maintenance safety instructions included in this manual.
- Be sure there are no tools lying on or in equipment.
- Do not use equipment until you are sure that area is clear, especially around children and animals.
- Don't hurry learning process or take equipment for granted. Ease into it and become familiar with your new equipment.
- Practice operation of your equipment and its attachments. Completely familiarize yourself and other operators with its operation before using.

- Make sure that drum brakes are evenly adjusted.
- Make sure tow rating on vehicle is high enough for what it is towing.
- Do not allow anyone to stand between tongue or hitch and towing vehicle when backing up to equipment.
- Securely attach to towing vehicle. Use appropriately sized hitch ball and hitch pin with a mechanical retainer and attach safety chains.
- Criss cross chains under tongue and secure to draw bar cage, mounting loops, or bumper frame.
- Never move trailer to tow vehicle, instead always back tow vehicle to trailer..



DURING OPERATION

- **SAFETY CHAINS** If equipment is going to be transported on a public highway, safety chains should be obtained and installed. Always follow state and local regulations regarding safety chains and auxiliary lighting when towing equipment on a public highway. Be sure to check with local law enforcement agencies for your own particular regulations. Only safety chains (not an elastic or nylon/plastic tow straps) should be used to retain connection between towing and towed equipment in event of separation of primary attaching system.
- Install safety chains by criss crossing chains under tongue and secure to draw bar cage, mounting loops, or bumper frame.
- Beware of bystanders, **PARTICULARLY CHILDREN!** Always look around to make sure it is safe to start engine of towing vehicle or move equipment. This is particularly important with higher noise levels, as you may not hear people shouting.
- **NO PASSENGERS ALLOWED-** Do not carry passengers anywhere on or in equipment.
- Do not clean, lubricate, or adjust your equipment while it is moving.
- When halting operation, even periodically, set towing vehicles parking brake, shut off engine, and **remove the ignition key**.
- Be extra careful when using on inclines.
- **MANEUVER TOWING UNIT AT SAFE SPEEDS.**
- Avoid loose gravel, rocks, and holes, they can be dangerous for equipment operation or movement.
- Allow for overall length when making turns.
- Keep all bystanders and pets clear of work area.

- Operate towing vehicle from operators seat only.
- Never leave running equipment attachments unattended.
- As a precaution, always recheck hardware on equipment following every 100 hours or 50 miles. Correct all problems. Follow maintenance safety procedures.



FOLLOWING OPERATION

- Following operation, or when unhitching, stop towing vehicle, set brakes, shut off the engine and remove ignition key.
- Store unit in an area away from human activity.
- Do not permit children to play on or around stored unit.
- Make sure all parked units are on a hard, level surface and engage all safety devices.
- Wheel chocks may be needed to prevent unit from rolling.
- Make sure actuator is in its full extended position to preclude from master cylinder rust.



HIGHWAY AND TRANSPORT OPERATIONS

- Adopt safe driving practices:
 - Always drive at a safe speed relative to local conditions and ensure that your speed is low enough for an emergency stop.
 - Reduce speed prior to turns to avoid risk of overturning.
 - Always keep towing vehicle in gear to provide engine braking when going downhill. Do not coast.
 - Do not drink and drive!
- Comply with state and local laws governing highway safety on public roads.
- Use approved accessory lighting, flags and necessary warning devices to protect operators of other vehicles on highway during transport. Various safety lights and devices are available from your dealer.
- Local laws should be checked for all highway lighting and marking requirements.
- Plan your route to avoid heavy traffic.

- Be a safe and courteous driver. Always yield to oncoming traffic in all situations, including narrow bridges, intersections, etc.
- Be observant of bridge loading ratings. Do not cross bridges rated lower than the gross weight at which you are operating.
- Watch for obstructions overhead and side to side while transporting.
- Always operate equipment in a position to provide maximum visibility at all times. Make allowances for increased length and weight of equipment when making turns and/or stopping.



DISMANTLING ACTUATOR

Note: Read and understand this section before attempting to disassemble actuator.

- Extend actuator and unscrew brake line fitting from rear of master cylinder. Note: Brake fluid escaping from master cylinder and brake line will damage paint. Care should be taken to protect painted surfaces.
- Remove the two 5/16" bolts that attach the brake away lever assembly to the top of the actuator outer housing. Remove the lever from the housing by sliding it backwards until the cross pin on the lever can fit through the T-slot on the housing.
- Remove one retaining ring and washer from each of the four pins located on the side of the actuator outer housing and slide pins out.
- Pull on inner slide assembly to remove from outer housing. Internal components can now be removed and dismantled for inspection, maintenance or repair or the entire inner slide assembly can be replaced.



ACTUATOR ASSEMBLY

- Before the inner slide assembly can be inserted into the outer housing, all internal components must be assembled and placed in their proper position.
- Lightly grease upper and lower wear pads before assembly.
- If the back of the outer housing is accessible, slide the inner slide assembly into the outer housing and from the back side of the outer housing, reach in and guide the master cylinder onto the welded shelf support. Insert lightly greased pin through rear top hole in the outer housing to hold master cylinder and black plastic spacer tubes in place.
- If the back of the outer housing is not accessible, first install master cylinder (with pushrod and black plastic spacer tubes attached) into the outer housing and set on welded shelf support. Insert lightly greased pin through rear top hole in the outer housing to hold master cylinder and black plastic spacer tubes in place. Slide the inner slide assembly into the outer housing.
- Insert lightly greased pin through rear bottom hole in the outer housing to hold shock absorber place.

- Insert lightly greased pins through the two forward top and bottom holes in the outer housing.
- Assemble washers and retaining rings on all pins.
- Install brake away lever assembly on top of outer housing and secure with the two 5/16" bolts.
- Connect brake line fitting.
- Bleed brake system



PERFORMING MAINTENANCE

- Good Maintenance is your responsibility. Poor maintenance is an invitation to trouble.
- Make sure there is plenty of ventilation. Never operate engine of towing vehicle in a closed building. Exhaust fumes may cause asphyxiation.
- Before working on this unit, stop towing vehicle, set parking brakes, shut off engine and **remove ignition key.**
- Be certain all moving parts and attachments have come to a complete stop before attempting to perform maintenance.
- Always use safety supports and block wheels. Never use a jack to support unit.
- Always use proper tools or equipment for job at hand.
- Use extreme caution when making adjustments.
- Openings in skin and minor cuts are susceptible to infection from brake fluid. **Without immediate medical treatment, serious infection and reactions can occur.**
- After servicing, be sure all tools, parts and service equipment are removed.
- Where replacement parts are necessary for periodic maintenance and servicing, genuine factory replacement parts must be used to restore your equipment to original specifications. Manufacturer will not claim responsibility for use of unapproved parts or accessories and other damages as a result of their use.
- If equipment has been altered in any way from original design, manufacturer does not accept any liability for injury or warranty.

MODEL UFP ACTUATOR PARTS BREAKDOWN

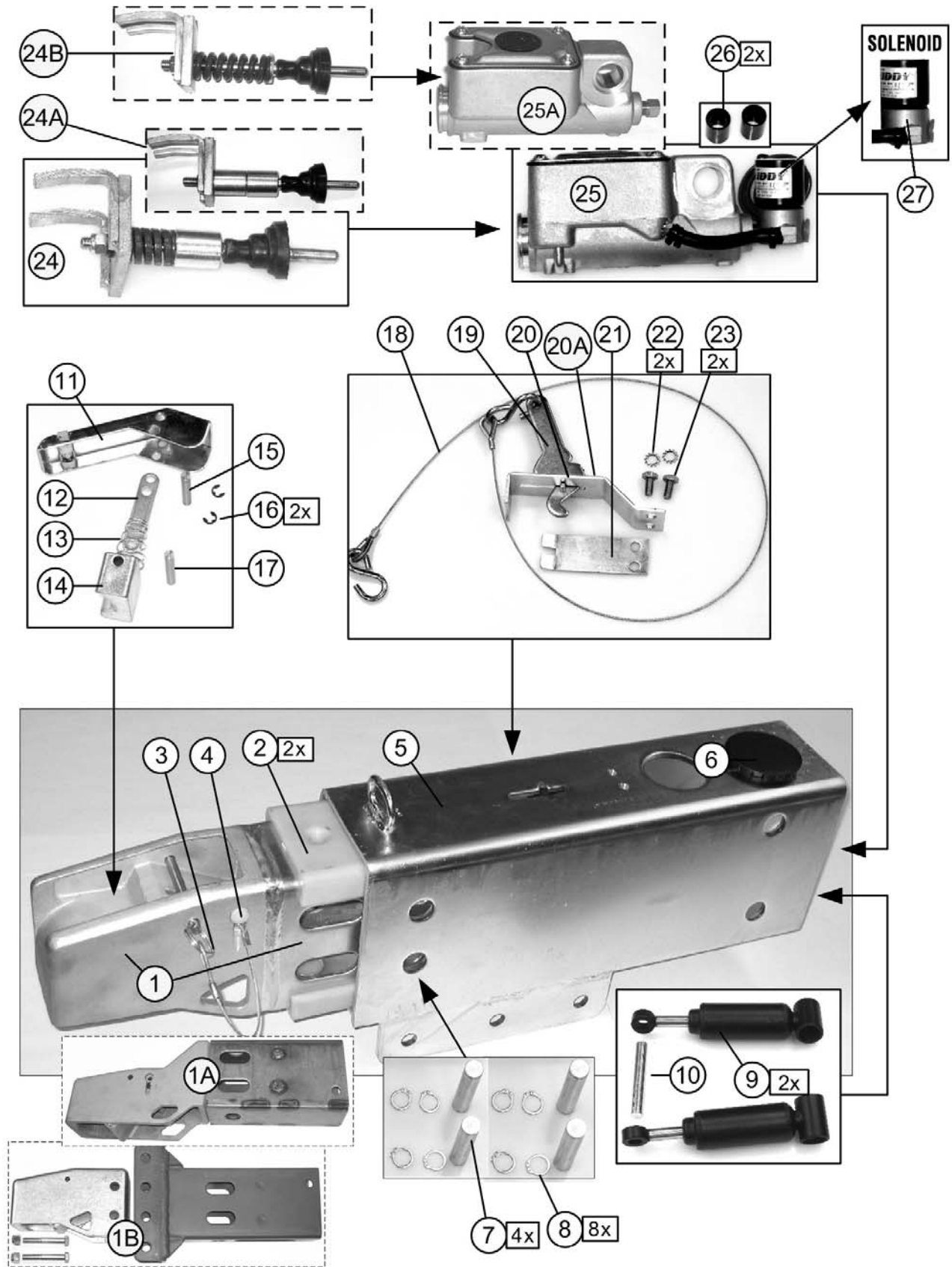

MODEL UFP160 ACTUAL PARTS LIST

KEY NO.	PART NO.	PARTS	Q'TY
1	19050S	IM, STRAIGHT, PLATED	1
1A	19050D	IM, DROP, PLATED	1
1B	19050B	IM, BOLT-ON,W/COUPLER, INNER SLIDE & 2 BOLTS 9/16-12 X 4.5" + 2 LOCK NUTS	1
2	19023	SLIDE BEARING	2
3	19041	LANYARD, HITCH PIN, SAFETY	1
4	19042	BUTTON, SNAP, LANYARD	1
5	19034	OUTER CASE ASSEMBLY	1
6	19010	CAP, PLASTIC	1
7	19014	PIN, SHOCK ABSORBER, REAR	4
8	32262	RETAINER RING	8
9	32306	SHOCK ABSORBER	2
10	19003	PIN, SHOCK ABSORBER, FRONT	1
11	19066	LATCH HANDLE W/ DEAD BOLT	1
12	19067	LINK, BALL LOCK/LATCH	1
13	19068	SPRING, LINK, LATCH HANDLE	1
14	19069	BALL LOCK SUPPORT	1
15	19070	PIN, LATCH HANDLE	1
16	19071	CLIP, RETAINER, LATCH PIN	2
17	19072	PIN, BALL LOCK SUPPORT	1
18	19005	BREAKAWAY CABLE ASSEMBLY	1
19	19006	BREAKAWAY LEVER	1
20	19011	LEVER GUIDE	1
20A	32522	DECAL, BREAKAWAY LEVER, RED/GREEN	1
21	19012	SAFETY STOP PLATE	1
22	19009	TOOTH WASHER	2
23	19008	BOLT, HEX 5/16	2
24	19073	TANDEM DISC PUSH ROD ASSY	1
24A	19074	TRIPLE DISC PUSH ROD ASSY	1
24B	19075	DRUM BRAKE PUSH ROD ASSY	1
25	32762	M/C-E-DISC ASSY	1
25A	32747	M/C-S, 1" DRUM ASSY	1
26	19018	SPACER, M/C,A160	2
27	34500	SOLENOID VALVE ASSY	(optional)

WELDING

NOTE: disassembly of the actuator before welding is recommended.

Tack Actuator down on the four corners then weld in a criss cross pattern using 2" to 2-1/2" welds with 2" spaces between welds (when welding down to a flat area of the tongue)

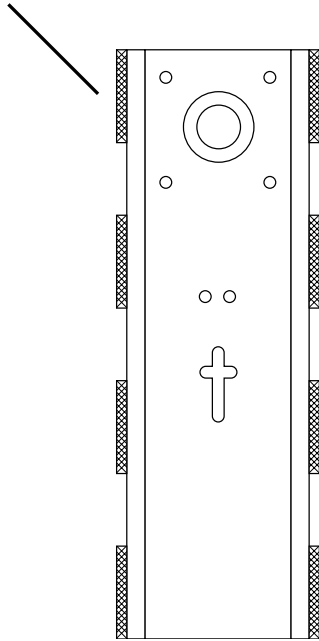

Use gussets to support the back of the actuator if welding in position shown

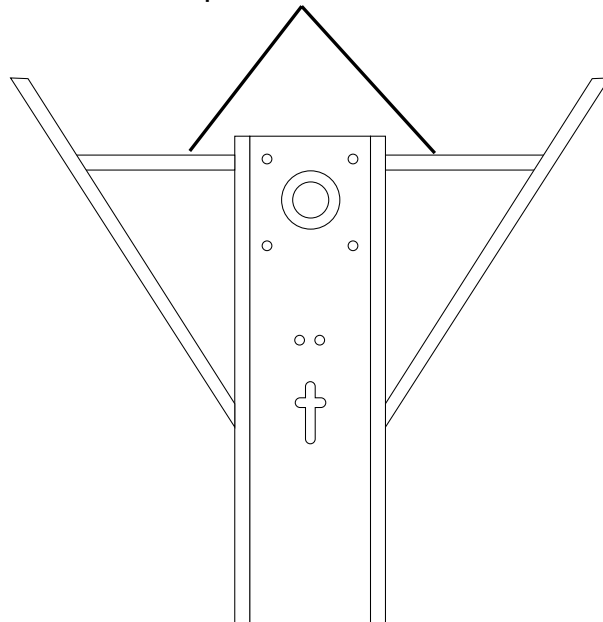

Weld as shown

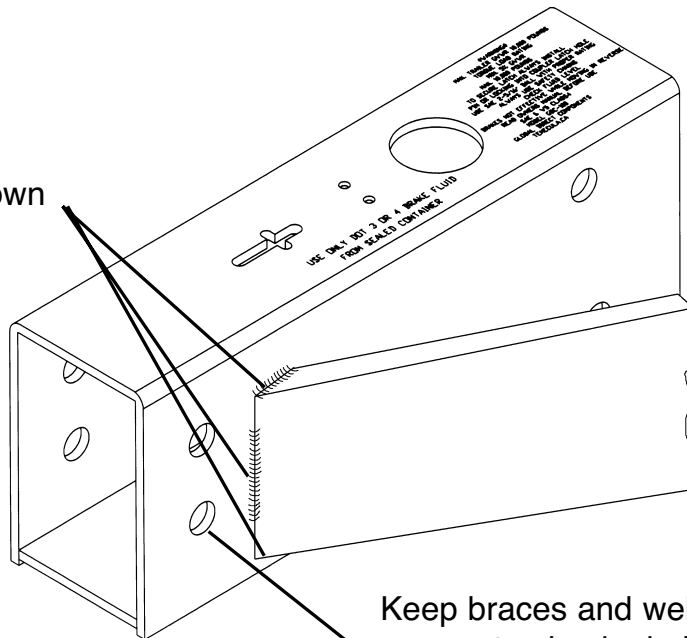

Keep braces and welds back to allow access to shock pin holes

OUTER CASE OPTIONS AND AVAILABLE HITCH CONFIGURATIONS

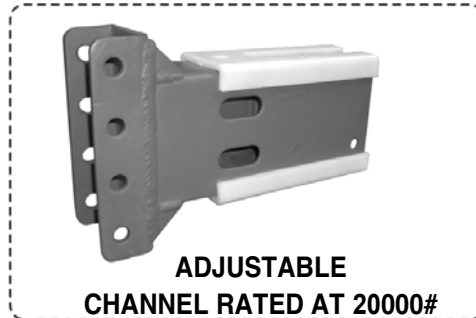
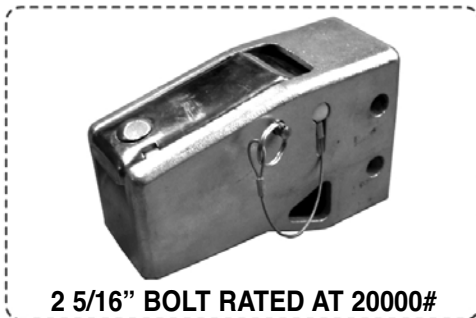
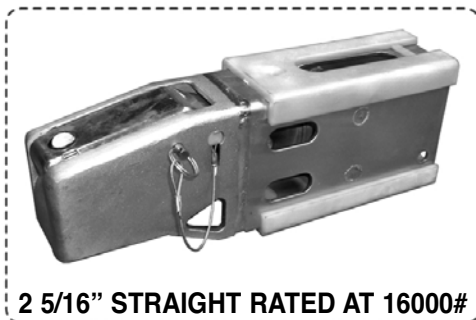
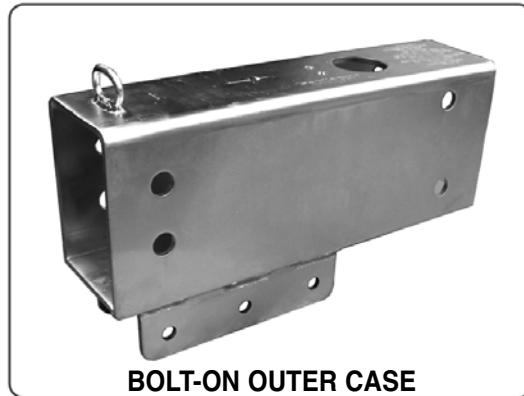

! WARNING: TO AVOID PERSONAL INJURY OR PROPERTY DAMAGE, OBSERVE THE FOLLOWING INSTRUCTIONS:

The weight rating of the coupler is dependent on the correct bolts being used. You must use 3, Grade 5, 1/2" mounting bolts only. If you are missing bolts, replace them immediately. Using the wrong size, grade, or number of bolts will reduce the weight rating of the coupler and could cause separation of your towing equipment from the towing vehicle.

UFP MODEL A-160 BRAKE ACTUATOR



WARNING To Prevent Serious Injury Or Death:

- Review all of the following instructions before installation and use of hydraulic brake actuator.
- Dealers or Distributors must review these instructions with ultimate user.
- Failure to follow these instructions, or failure to properly maintain braking system after installation, can result in loss of braking action which could cause severe property damage, personal injury or death.

Model A-160 brake actuator has a maximum load rating of 16,000 lbs. GVWR and 1000 lbs. tongue load.



WARNING To avoid personal injury or death, do not exceed lowest of (1) the rated capacity of actuator, or (2) rated capacity of ball, hitch and coupler being used, or (3) trailer's Gross Vehicle Weight Rating (GVWR).

INSTALLATION

Model A-160 – Bolt-on comes completely assembled and ready to bolt into place.

1. The A-160 actuator comes in a variety of models. (see Page 13).
2. Connect and tighten all brake lines.
3. Fill master cylinder with DOT 3 or 4 brake fluid.
4. Bleed brake system using a pressure-type brake bleeder or manually, as follows:
 - a. Remove two 5/16" hex head bolts (#23) and lock washers (#22) that hold lever guide (#20) and flat safety stop plate (#21). Remove lever guide and safety stop plate. Using short strokes, pull forward on emergency lever (#19), pumping master cylinder until brake fluid within master cylinder stops bubbling.
 - b. Attach a bleeder hose to bleeder screw on the brake furthest from the actuator and submerge other end of hose into a transparent container partially filled with brake fluid. Loosen bleeder screw and, watching hose in transparent container, use emergency lever to pump master cylinder. Close bleeder screw before releasing lever at master cylinder. Continue process until no more bubbles are released from bleeder screw. Move to next wheel, and repeat process until all brakes have been bled. (Note: Check fluid level in master cylinder frequently while bleeding brakes (every 4 or 5 strokes). Refill as necessary to keep level above half full.)

5. Once bleeding is completed, refill master cylinder and attach cap (#6) secure reservoir cap. Replace emergency lever spring, lever guide, lock washers and 5/16" hex head bolts.
6. Test brakes by pulling emergency lever (#19) forward until it locks into its second notch position. (Lever should be approximately straight up.) Attempt to rotate wheels in a forward direction. If any wheels rotate, brakes must be adjusted (drum style only) or system needs to be rebled. Repeat test procedure as necessary.

MAINTENANCE

1. Frequently check brake fluid level. (Fluid must be approved, clean and uncontaminated.)
2. Make sure actuator mounting bolts are secure.
3. Inspect actuator, replace bent, worn or damaged parts.
4. Be constantly aware of systems braking quality, make periodic checks as described in brakes owners manual. Consult certified brake specialist to make necessary adjustments or repairs. Failure to do so could result in loss of braking.

SERVICING THE EMERGENCY LEVER

If emergency lever (#19) of actuator is applied, it can be disengaged by using a screwdriver to lift upward on front of flat safety stop plate (#21) while pulling lever forward until released. A thorough inspection of emergency lever, safety stop plate, and cable with S-hooks is required. Damaged parts must be replaced as follows:

- A. Remove Cable S-hook from emergency lever (#19), emergency lever guide (#20) and flat safety stop plate (#21), then pull lever out of actuator outer case (#5) through cross-slot in top.
- B. Install new emergency lever through cross-slot in top of outer case. Attach new emergency lever spring and emergency lever guide.
- C. Insert S-hook on emergency cable (#18) into hole in emergency lever (#19) and squeeze shut.
- D. Add adequate brake fluid to master cylinder and bleed brake system per instructions 4-6 in installation section.