



# REFLEX STS™

STABILITY & RIDE CONTROL



**ENGINEERED  
FOR STRENGTH & STABILITY**

**TRUSTED STABILITY. LASTING COMFORT.  
PROVEN DURABILITY.**

- » Reinforced cross member and heavy-duty shocks work together to cut bounce, sway, and frame stress.
- » Premium components and easy bolt-on installation deliver a safer, smoother ride while protecting your RV and everything inside.

[WWW.DEXTERGROUP.COM](http://WWW.DEXTERGROUP.COM)

# SMOOTH. STABLE. STRONG.

## » THE DIFFERENCE FOR EVERY MILE

### Integrated Stability Cross Member

- Reinforces structure between axles.
- Reduces lateral flex and frame distortion under load.

### Heavy-Duty Shock Absorbers

- Tuned specifically for RV trailer dynamics.
- Minimizes bounce, sway, and road vibration.

### Durable Construction

- High-strength steel cross member with corrosion-resistant finish.
- Shock components tested for long service life.

### Improved Towing Stability

- Minimizes wobble for safer highway driving.
- Reduces driver fatigue by improving control.

### Extended RV & Component Life

- Less vibration means less wear on tires, axles, and suspension components.
- Protects interior finishes, electronics, and structural joints.

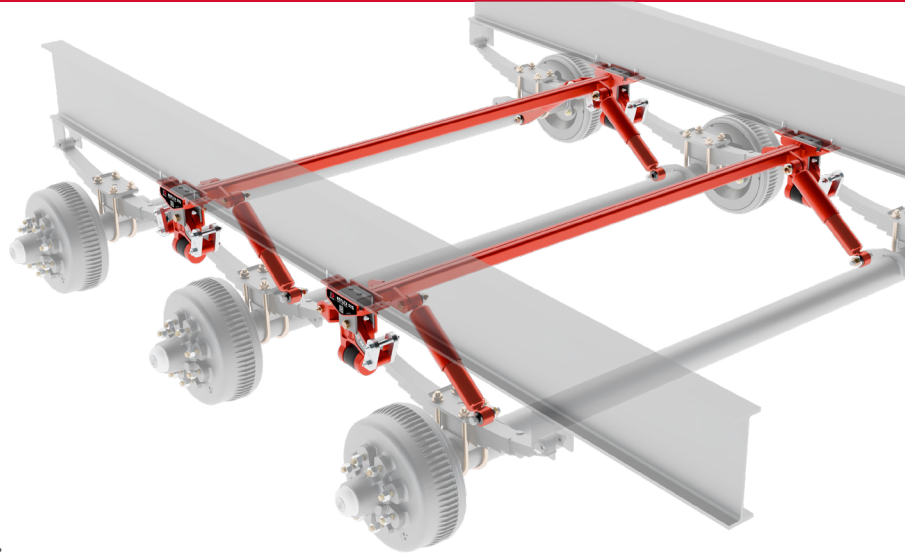

## » BUILT FOR A SMOOTHER, SAFER RIDE

Dramatically reduces trailer rebound and “chucking” on rough roads, helping keep cabinets, furniture, and belongings more secure.

SCAN TO  
LEARN  
MORE

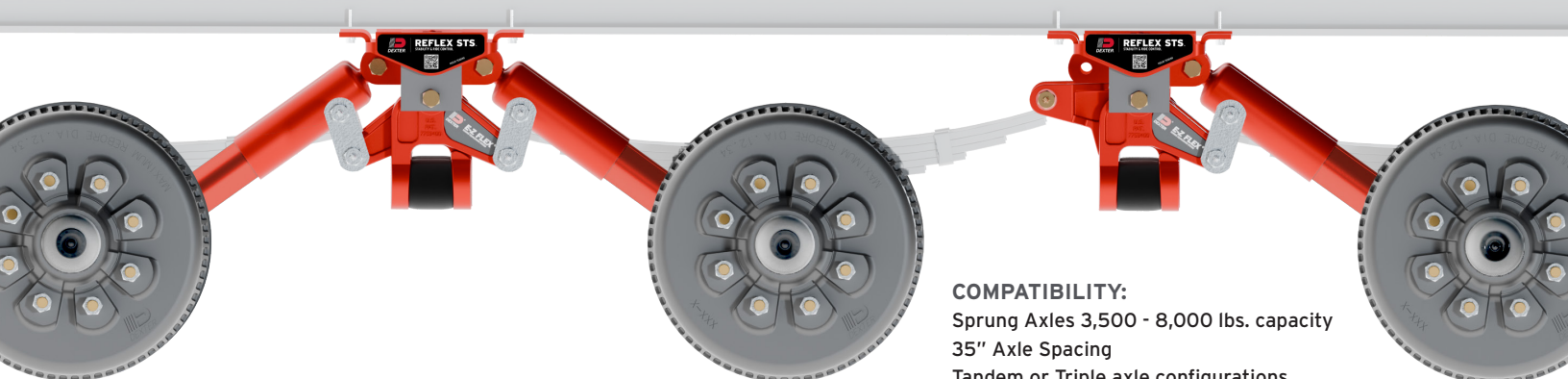

**COMPATIBILITY:**  
Sprung Axles 3,500 - 8,000 lbs. capacity  
35" Axle Spacing  
Tandem or Triple axle configurations